

# SIM800 GSM/GPRS Dev kit



Technical Manual Rev 1r0



## FEATURES:

**The SIM800 GSM/GPRS Development kit** is a quad-band GSM/GPRS module designed with power saving technique so that the current consumption is as low as 0.7mA in sleep mode. In application, controlling device controls the GSM engine by sending AT Command via its serial interface. One SIM card interface. One full function UART port, with programmable general purpose input and output. Support one PWM. Using FS application features a local storage space is mapped to the drive, where in the user can create directory in local drive and the storage space of SD card is mapped to the drive. The keypad interface consists of 5 columns output and 5 row inputs, module keys support 25 keys.

- Arduino Compatible
- Can be used for AT commands for data stream
- Full modem interface with status and control lines
- SIMCOM 800 Module
- On board manual power switch
- On board SIM Card and uSD Card slot

## GENERAL SPECIFICATIONS:

- Input Supply: 5-9VDC (External)
- Req. current: 1A-2.6A (External)
- Interface: **Serial communication**
- Normal Operation: (-40 degC to 85 degC)
- SIM interface: **Support SIM card 1.8V, 3V**
- Physical characteristics:
  - Size: 24mmX24mmX3mm
  - Weight: 3.2g
- PCB Dimensions: 64mmx64mm

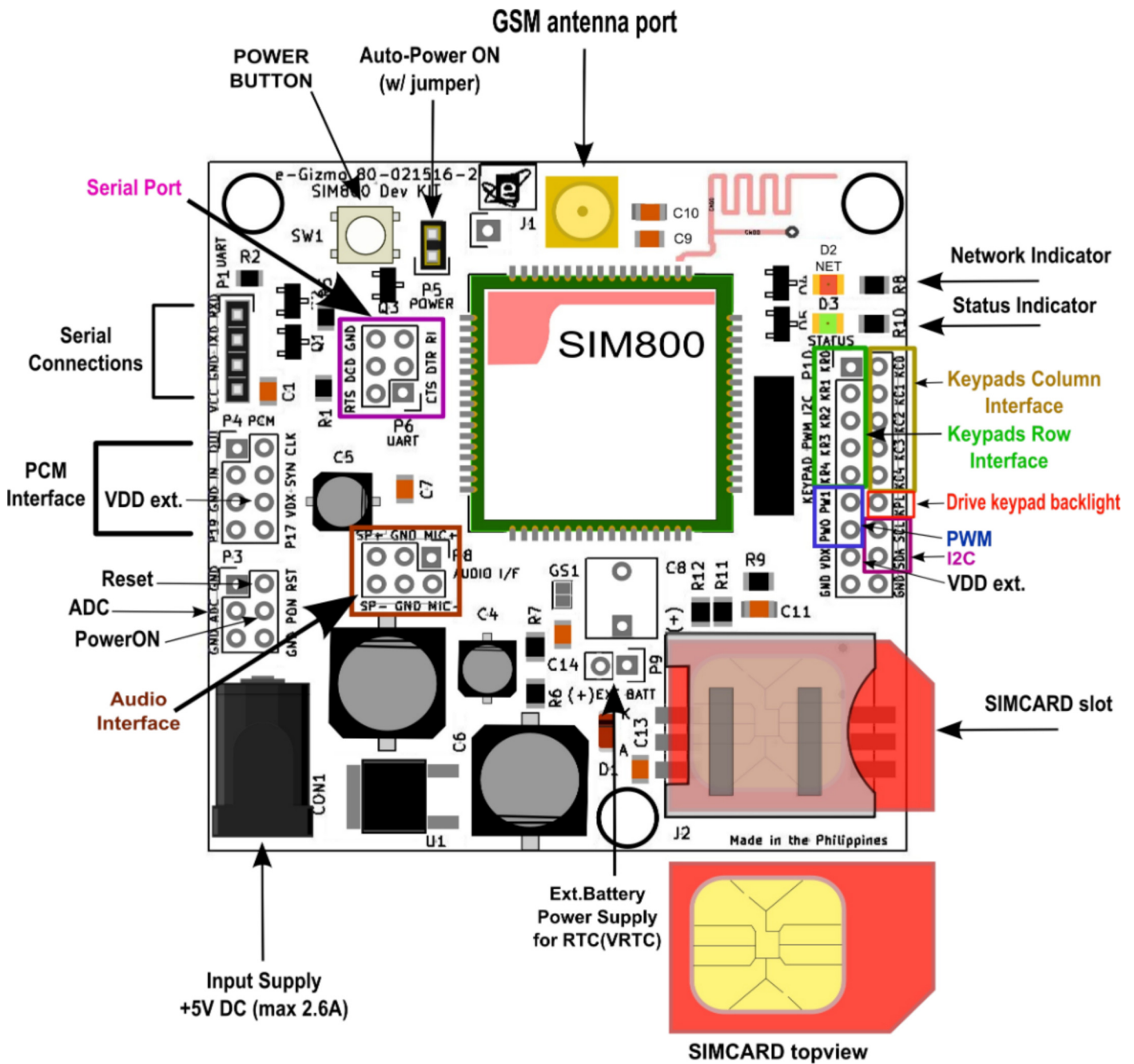
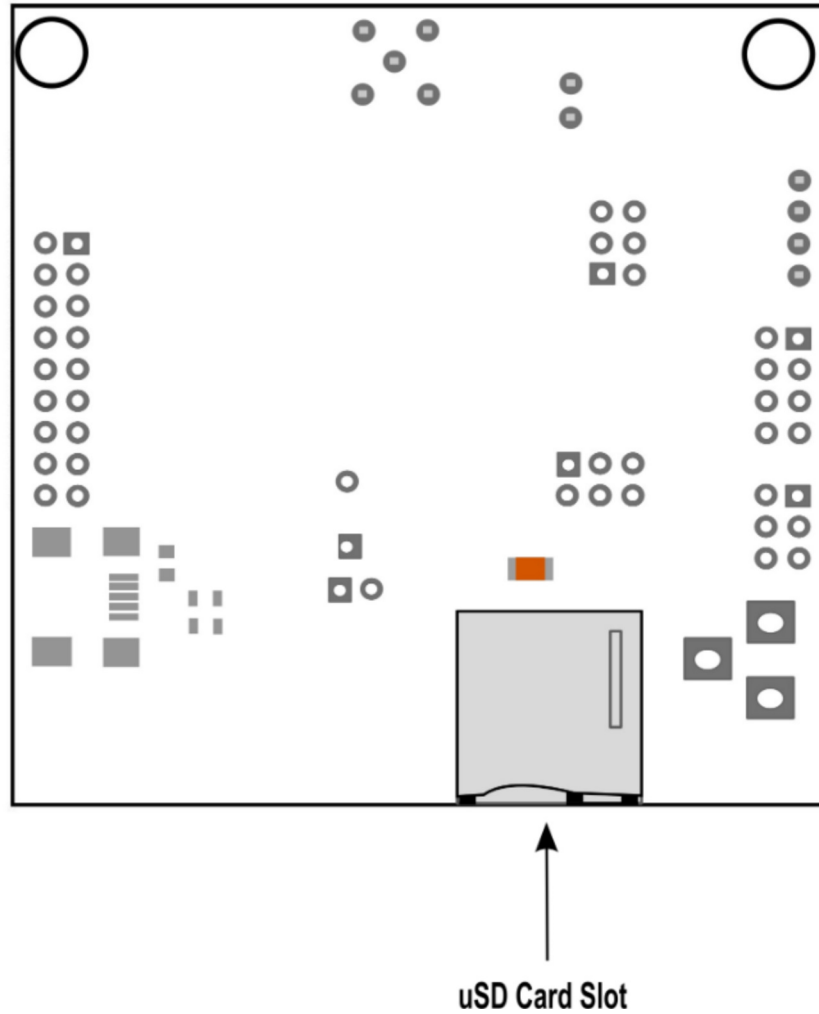

Figure 1. Major parts presentation of SIM800 GSM/GPRS Development kit.



**Figure 2.** Bottom View of SIM800 GSM/GPRS Dev kit.

**Table 1. P1 Serial Connection Descriptions**

<b>NAME</b>	<b>TYPE</b>	<b>DESCRIPTION</b>
RXD	Input	Receive Data
TXD	Output	Transmit Data
GND		Ground
VCC	Input	Power Input

**Table 2. P2 USB Interface Descriptions**

<b>NAME</b>	<b>TYPE</b>	<b>DESCRIPTION</b>
USB_VBUS	Input	Debug and firmware upgrading*
USB_DN	I/O	
USB_DP	I/O	
GND		Ground

**Table . P3 Descriptions**

<b>NAME</b>	<b>TYPE</b>	<b>DESCRIPTION</b>
RST	Input	Reset input(Active low)
ADC	Input	10-bit general analog to digital conv

**Table 4. P4 PCM Interface Descriptions**

<b>NAME</b>	<b>TYPE</b>	<b>DESCRIPTION</b>
OUT	Output	PCM interface for Audio*
IN	Input	
SYNC	Output	
CLK	Input	
VDX	Output	2.8V power output

(For GPIO17 and 19 see page 46 of SIM800-Hardware-Design-V1.08.pdf)

**Table 5. P5 Power Descriptions**

<b>NAME</b>	<b>TYPE</b>	<b>DESCRIPTION</b>
POWER	Input	Auto-Power ON (if with jumper)

**Table 6. P6 UART Descriptions**

<b>NAME</b>	<b>TYPE</b>	<b>DESCRIPTION</b>
DTR	Input	Data terminal ready*
RI	Output	Ring indicator*
DCD	Output	Data carrier detect*
CTS	Output	Clear to send*
RTS	Input	Request to send*

**Table 7. P7 RF Synchronization Descriptions**

<b>NAME</b>	<b>TYPE</b>	<b>DESCRIPTION</b>
RF_SYNC	Output	RF burst synchronous signal (Do not pull up)

**Table 8. P8 Audio Interface Descriptions**

NAME	TYPE	DESCRIPTION
SP+	Output	Differential audio output*
SP-	Output	Differential audio output*
MIC+	Input	Differential audio input*
MIC-	Input	Differential audio input*

**Table 9. P9 Ext. Batt Descriptions**

NAME	TYPE	DESCRIPTION
Ext.Batt	I/O	Power supply for RTC*

**Table 10. P10 KEYPAD PWM I2C Descriptions****KEYPAD Interface**

NAME	TYPE	DESCRIPTION
COLUMNS		
KC0	Input	Support up to 50 buttons (5*5*2)*
KC1	Input	
KC2	Input	
KC3	Input	
KC4	Input	
ROWS		
KR0	Output	
KR1	Output	
KR2	Output	
KR3	Output	
KR4	Output	

**PWM**

NAME	TYPE	DESCRIPTION
PWM0	Output	Pulse-width modulation, multiplex with GPIO22.*
PWM1	Output	Pulse-width modulation, multiplex with GPIO23.*

(For more info See page 47 of SIM800-Hardware-Design-V1.08.pdf)

**I2C**

NAME	TYPE	DESCRIPTION
SDA	I/O	I2C Serial bus data
SCL	Output	I2C Serial bus clock
KPLED	Input	Drive Keypad backlight
VDX	Output	2.8V power output*

**Table 11. LED Indicator Descriptions**

NAME	TYPE	DESCRIPTION
D2	NET	Network Indicator status
D3	STATUS	Power ON status Indicator

**Table 12. Antenna Descriptions**

NAME	TYPE	DESCRIPTION
J1	GSM_ANT	GSM antenna port
	BT_ANT	Bluetooth antenna port*

**NOTE: \*\*\*Keep floating if unused**

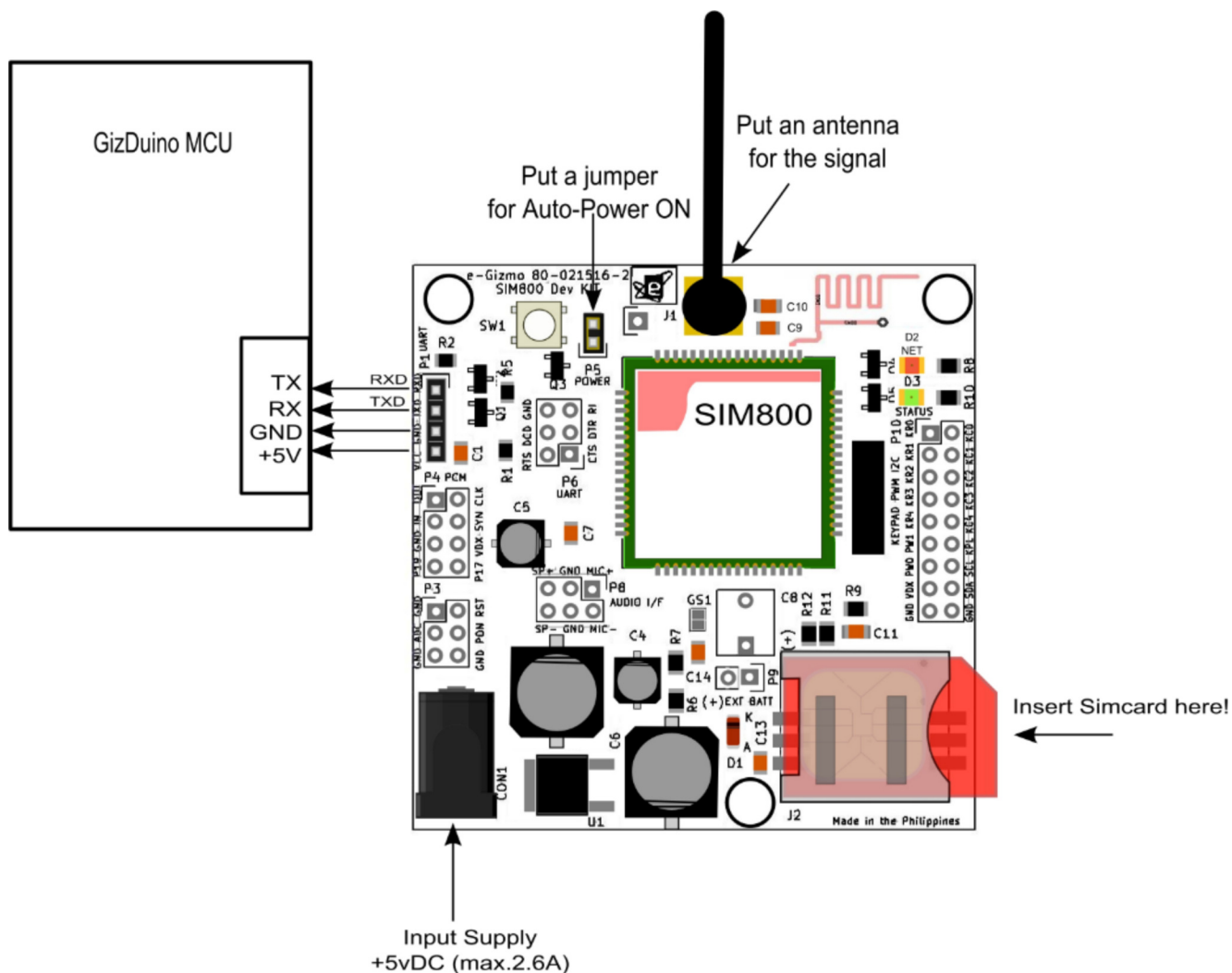

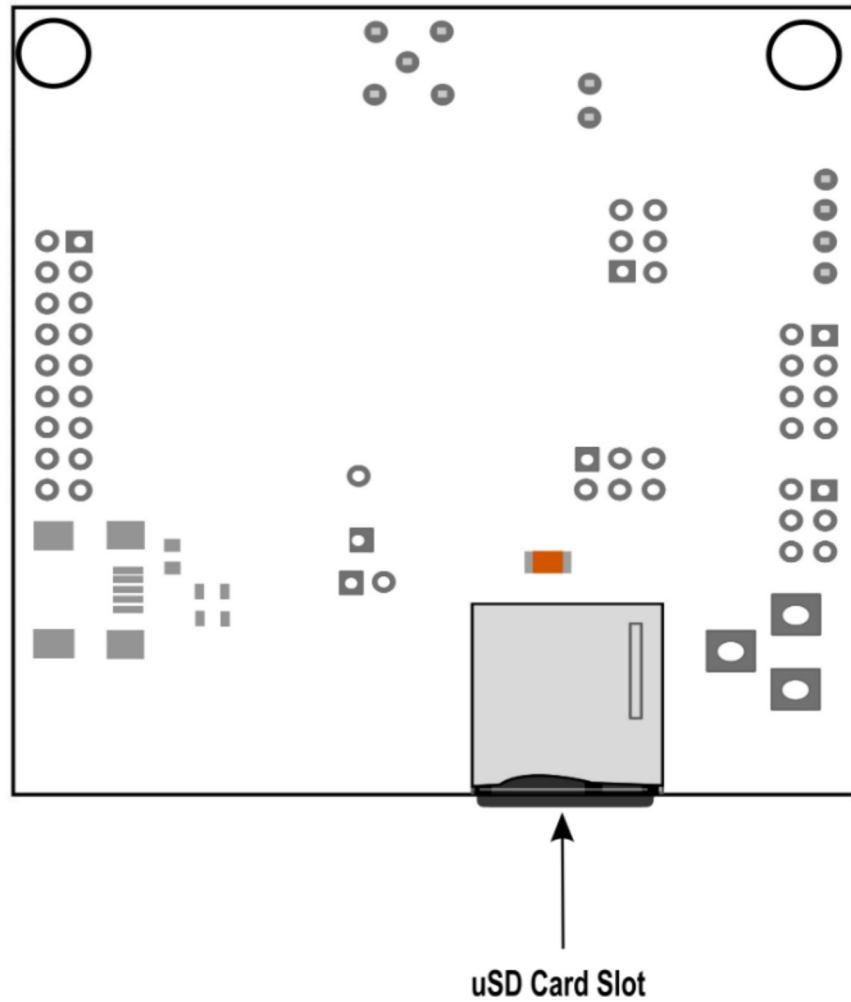

**Figure 4.** Bottom View of SIM800 GSM/GPRS Dev kit with uSD card inserted.

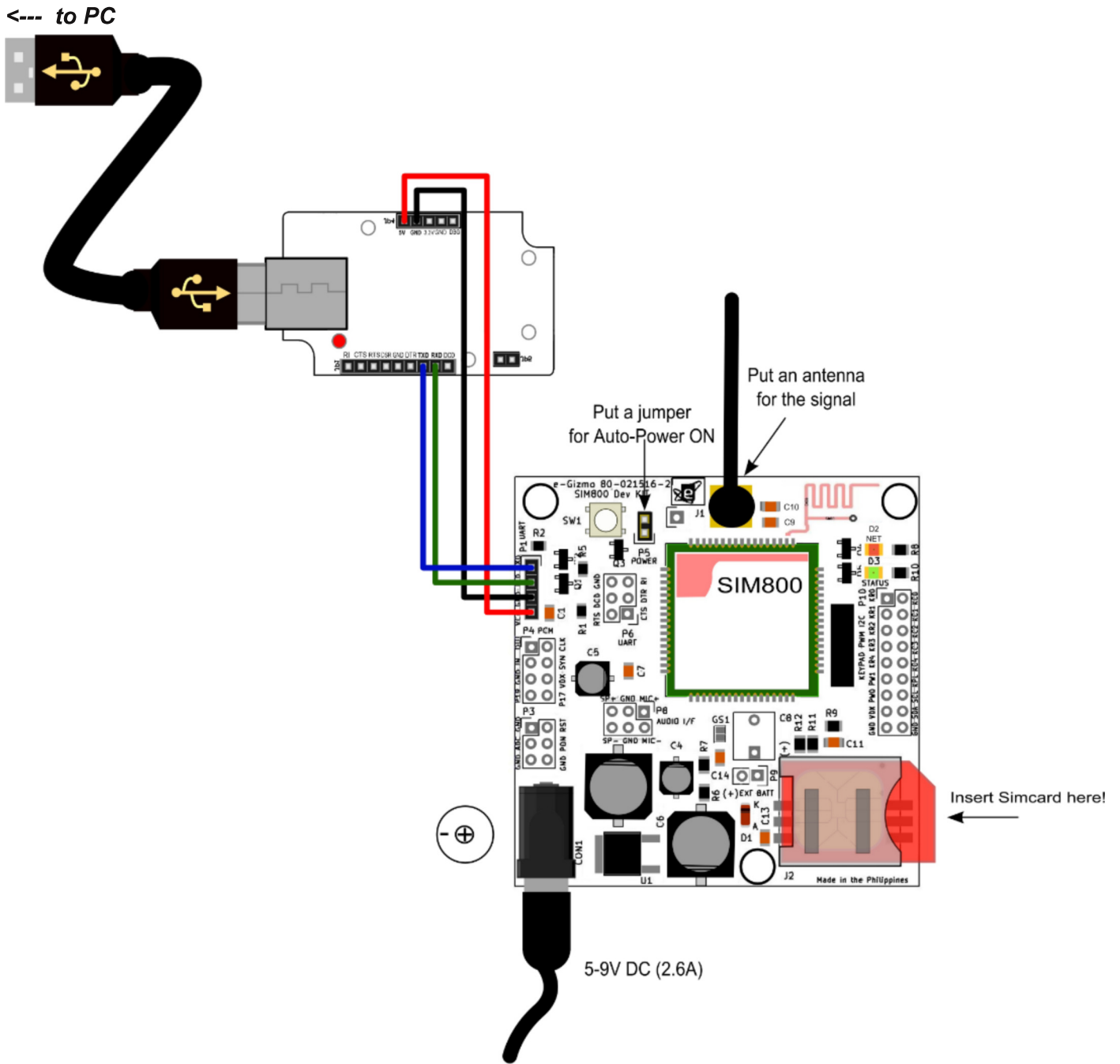
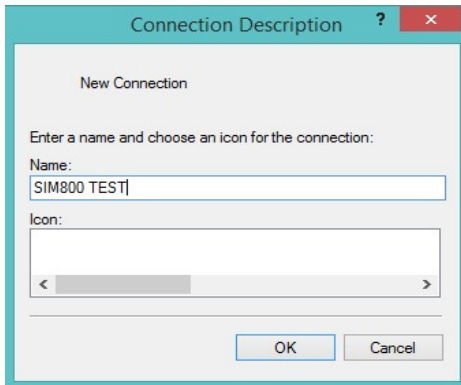

Figure 5. Sample Connection with USB-TTL converter.



**Open the HYPERTERMINAL.exe**



**1. Type Name: SIM800 TEST. Click OK.**

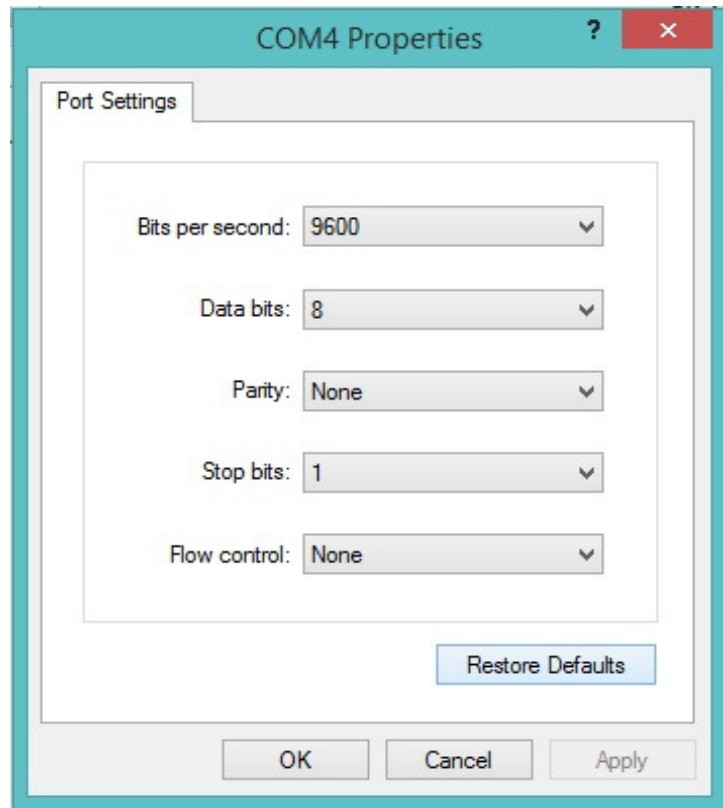

**3. Click the RESTORE DEFAULTS. 9600,8,None,1,None**



**2. Select the correct COMPORT. Click OK**

**Click OK.**

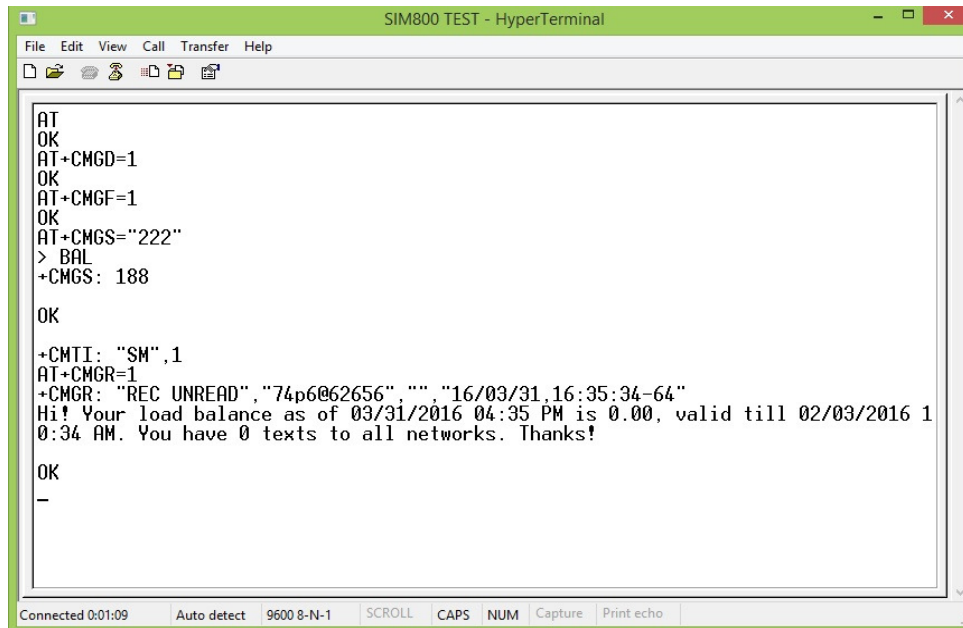

**4. Turn ON the CAPS LOCK mode. Type AT commands.**

**List of basic "AT commands"**

The characters <CR> represent a 'Carriage Return' command. It is simply an 'ENTER' key command on the keyboard.

TYPE	DESCRIPTION
<b>AT&lt;CR&gt;</b> OK	<i>This is just the commands previously done.</i>
<b>ATE1&lt;CR&gt;</b> OK	<i>This command tells the GSM Modem to echo the characters you type into the Hyper Terminal ,which allows the display of every character typed.</i>
<b>AT+CMGD=1&lt;CR&gt;</b> OK	<i>Delete an SMS message</i>
<b>AT+CMGF =1&lt;CR&gt;</b> OK	<i>This command tells the GSM Modem to display SMS messages in the Human Read able Text Format.</i>
<b>AT+CMEE=2&lt;CR&gt;</b> OK	<i>This command lets the GSM Modem report any errors found in a readable format.</i>
<b>AT+_CFUN=1&lt;CR&gt;</b> OK	<i>This command sets all the GSM Modem functions to be available to the user.</i>
<b>AT+COPS=0&lt;CR&gt;</b> OK	<i>This command lets the GSM Modem functions choose an available network operator automatically. The process may take some time to complete, and its completion is marked by the 'OK' response. This usually takes around 30 seconds to complete.</i>
<b>AT+CPAS&lt;CR&gt;</b> OK	<i>Whenever this command is executed during the processing time from the above command, it reports on the status of the loading process. When the GSM modem is still loading, it will respond with an 'OK'. Otherwise, if it is done it will respond 'Ready'. If the GSM modem responds ,an 'Error' up until a minute then the problem may result in the improper attachment of the SIM card. To remedy this, turn off the GSM modem power, carefully reattach the SIM card and check if it is properly placed, and resume with the start up process once again.</i>

<code>AT+CNUM&lt;CR&gt;</code>	Display SIM Number
<code>AT+COPS?&lt;CR&gt;</code>	Show operator network
<code>AT+CSQ&lt;CR&gt;</code>	Show signal quality
<code>AT+CMGL="ALL"&lt;CR&gt;</code>	Display all SMS messages [WARNING: If there are large amounts of SMS messages in the SIM card, this command will flood your HyperTerminal with SMS messages.]

**AT+CMGS="SIM number"<CR>** Send an SMS message  
For example, if the user types in `AT+CMGS="09123456789"` and executes 'ENTER', and types in for the message 'Hello There!' (excluding the apostrophes) and presses down both 'CTRL' and 'Z' simultaneously, the GSM modem will send a 'Hello There!' message to the desired number. Note that this will cost an amount of credit or load depending on the network service provider.

User Message:  
**PRESS**  
**<CTRL>+<Z>**

<code>AT+CMGR=1&lt;CR&gt;</code>	Display an SMS message [If there are no messages in storage of the SIM card, it will return an Error' message]
<code>AT+CLAC&lt;CR&gt;</code>	Show list of all available commands
<code>AT+CPOWD&lt;CR&gt;</code>	Switches GSM Module power to OFF

For more information regarding all the available commands of the GSM module, the user may refer to the SIM800 'AT Command' manual.

```
AT+SD2PCM=0          SD mode is valid
OK
AT&W
OK
AT+CFUN=1,1          reboot the module

AT+FSDRIVE=1          Get SD Card drive
+FSDRIVE:E
OK

AT+FSLs=E:\
Images\
Audio\
OK
AT+FSCREATE=E:\test.txt    Create test.txt
OK
AT+FSLs=E:\
Images\
Audio\
test.txt
OK
```

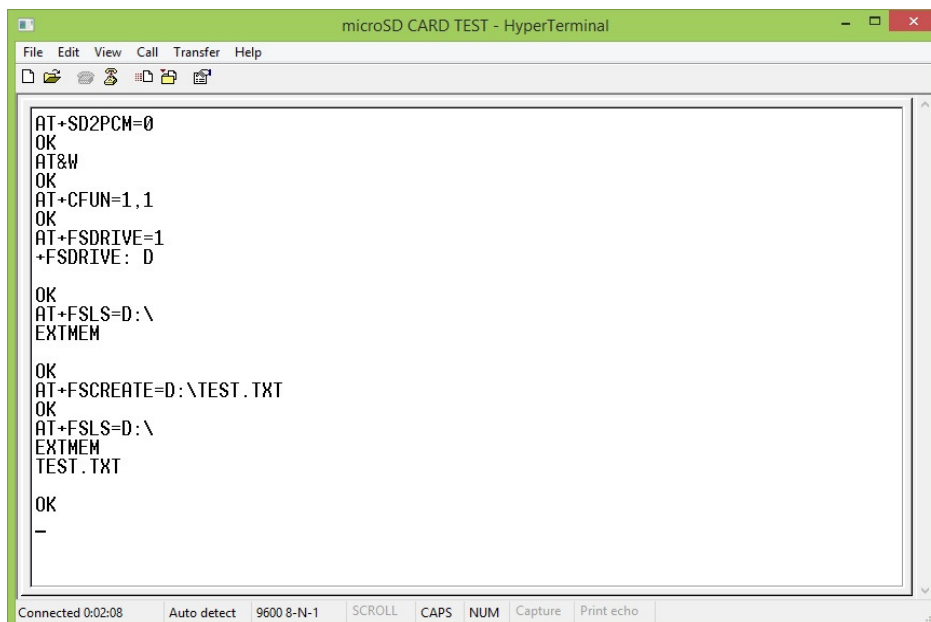

**Reference:** see page 13-14 the *SIM800 Series\_FS\_Application Note\_v1.01 datasheet*)

```
AT+FSFLSIZE=E:\test.txt
```

```
+FSFLSIZE: 20
```

```
OK
```

```
AT+FSREAD=E:\test.txt,0,100,1
```

```
qwertyuiopasdfghj
```

```
OK
```

```
AT+FSWRITE=E:\test.txt,0,2,10 Write "cc" at the beginning of the file
```

```
>
```

```
OK
```

```
AT+FSREAD=E:\test.txt,0,100,0 The first two characters is "cc"
```

```
ccertyuiopasdfghj
```

```
OK
```

```
AT+FSREAD=E:\test.txt,1,100,2 The offset of reading position is 2
```

```
ertyuiopasdfghj
```

```
OK
```

```
AT+FSMEM
```

```
+FSMEM: C:1024v=bytes,E:49152bytes
```

```
OK
```

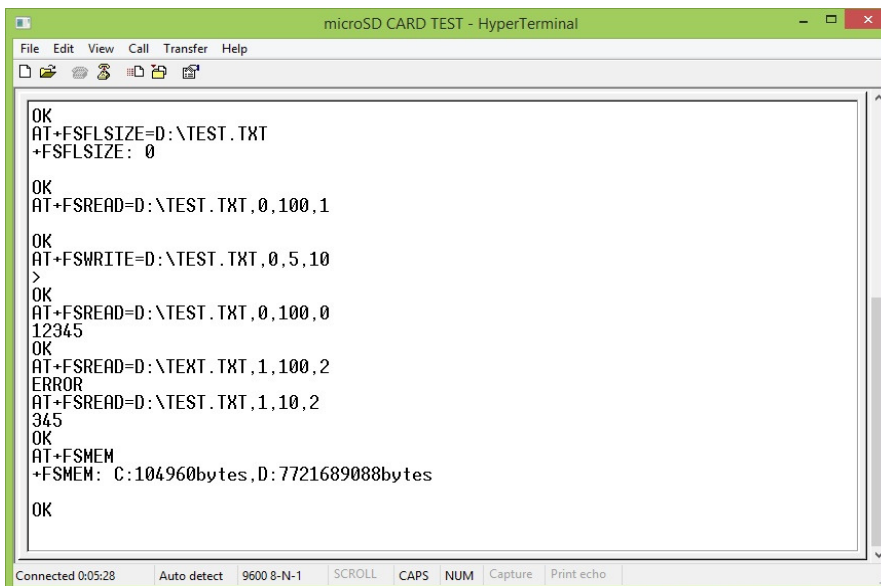

```
OK
AT+FSFLSIZE=D:\TEST.TXT
+FSFLSIZE: 0

OK
AT+FSREAD=D:\TEST.TXT,0,100,1

OK
AT+FSWRITE=D:\TEST.TXT,0,5,10
>

OK
AT+FSREAD=D:\TEST.TXT,0,100,0
12345

OK
AT+FSREAD=D:\TEXT.TXT,1,100,2
ERROR
AT+FSREAD=D:\TEST.TXT,1,10,2
345

OK
AT+FSMEM
+FSMEM: C:104960bytes,D:7721689088bytes

OK
```

```

AT+FSLs=E:\
test1.txt
OK
AT+FSMKDIR=E:\media           Make media directory
OK
AT+FSRENAME=E:\test1.txt,E:\test2.txt  Rename test1.txt
OK
AT+FSLs=E:\
test2.txt
media\
OK
AT+FSRMDIR=E:\media           Delete media directory
OK
AT+FSLs=E:\
test2.txt
OK
    
```

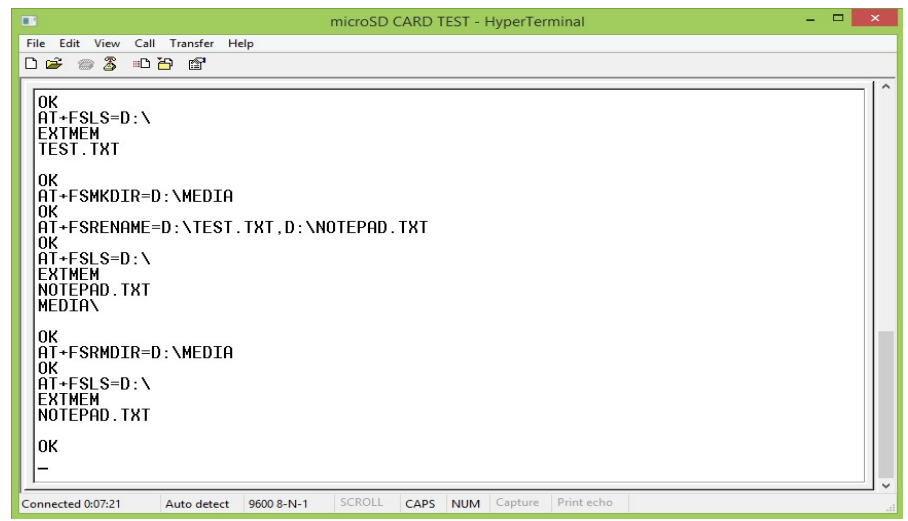
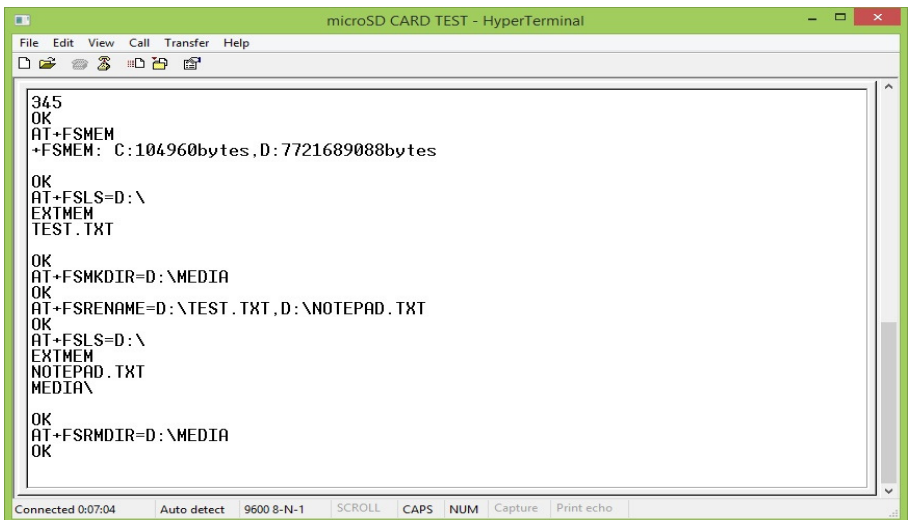

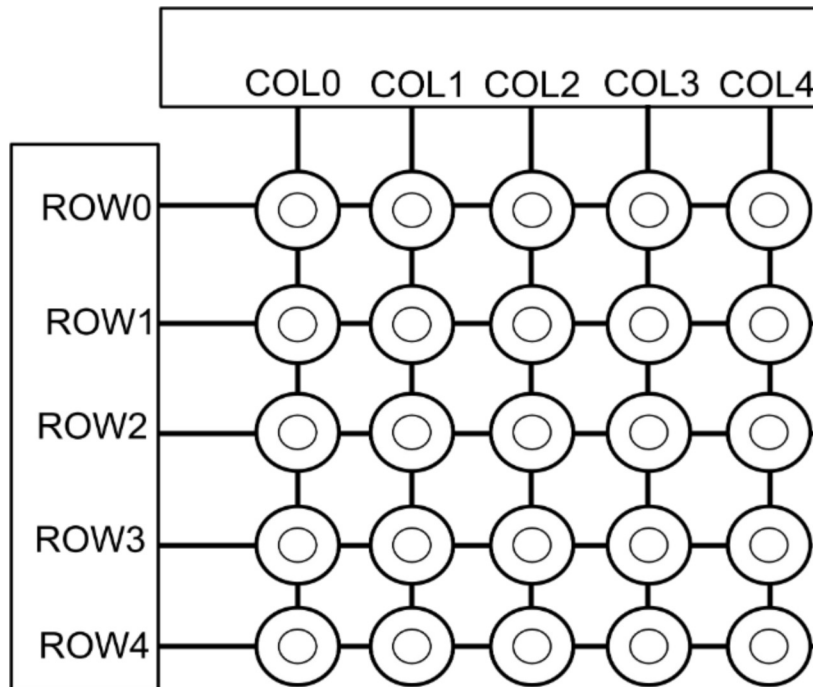

TYPE	DESCRIPTION
<i>AT+SKPD=?</i> <i>+SKPD: (0-1)</i>	<i>Keypad Detecting Function</i>
<i>AT+SKPD?</i> <i>+SKPD: &lt;mode&gt;</i>	<i>Display keypad mode</i>
<i>AT+SKPD=&lt;mode&gt;</i> <i>OK</i> <i>ERROR</i>	<p><i>If key has pressed or released, The URC report is:</i></p> <p><i>+SKPD: &lt;value&gt;,&lt;event&gt;</i></p> <p><b>0</b> - Disable Keypad detecting function  <b>1</b> - Enable Keypad detecting function  <b>&lt;value&gt;</b> The value of pressed or released keypad  <b>&lt;event&gt;</b> The status of keypad              0 - Key released              1 - Key pressed</p>

The Keypad interface consists of 5 keypad column outputs and 5 keypad row inputs. Module keys supports 25 keys.

**Reference:** AT commands for keypad. See page 193 of *SIM800\_Series\_AT\_Command\_Manual\_V1.0.5.pdf*

# SCHEMATIC DIAGRAM OF SIM800 DEV MODULE KIT

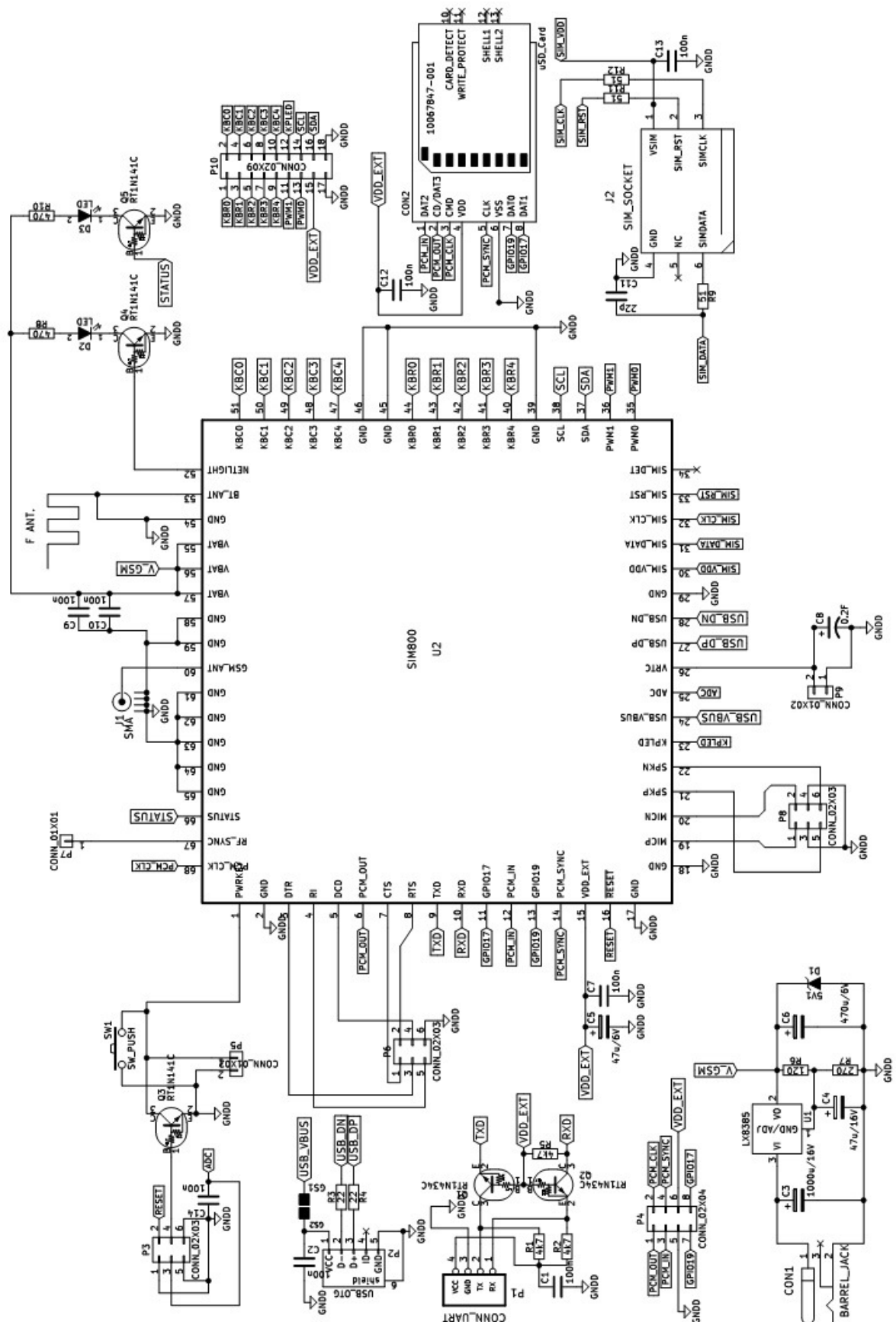



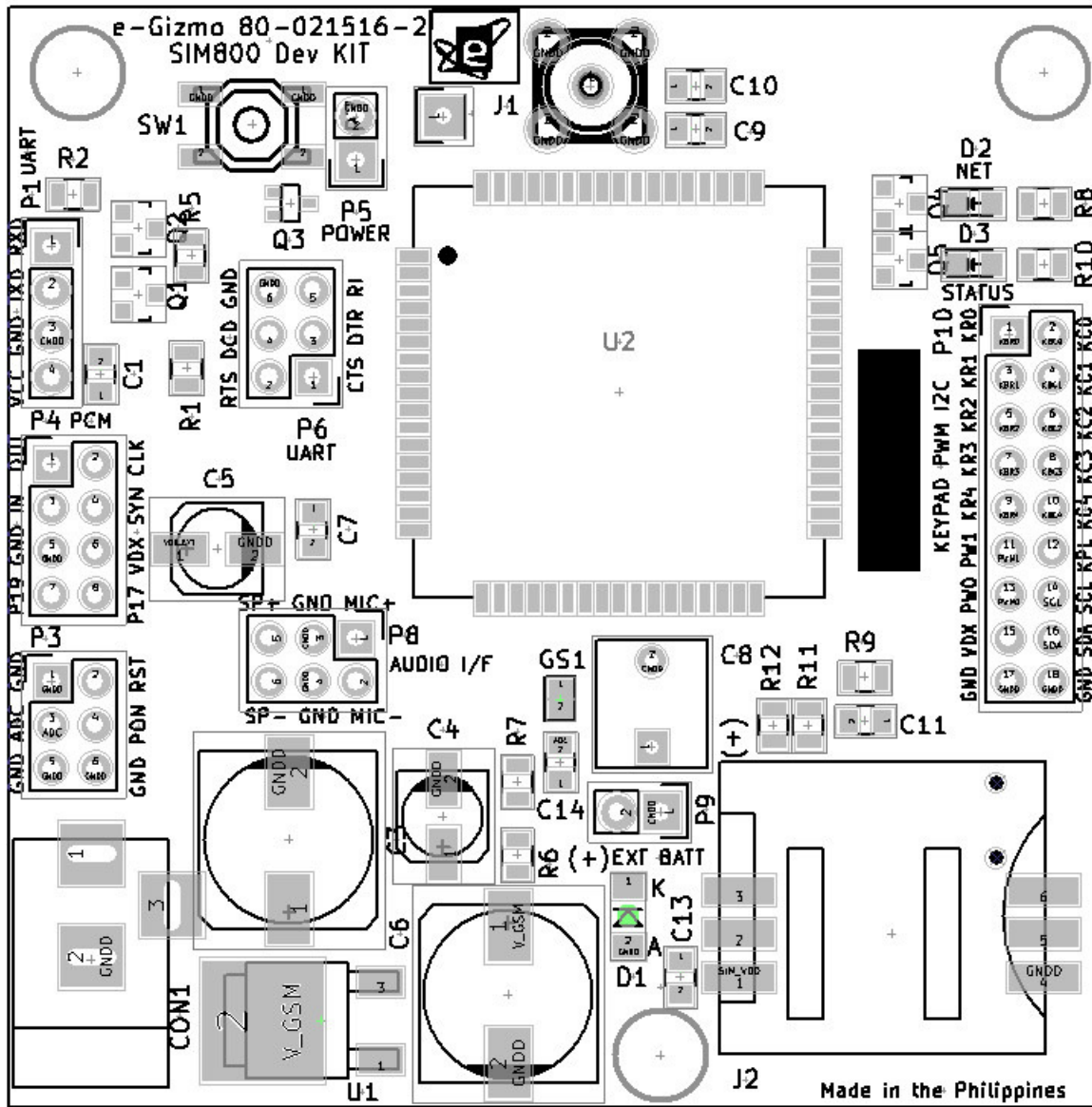

Figure 6. Parts Placement

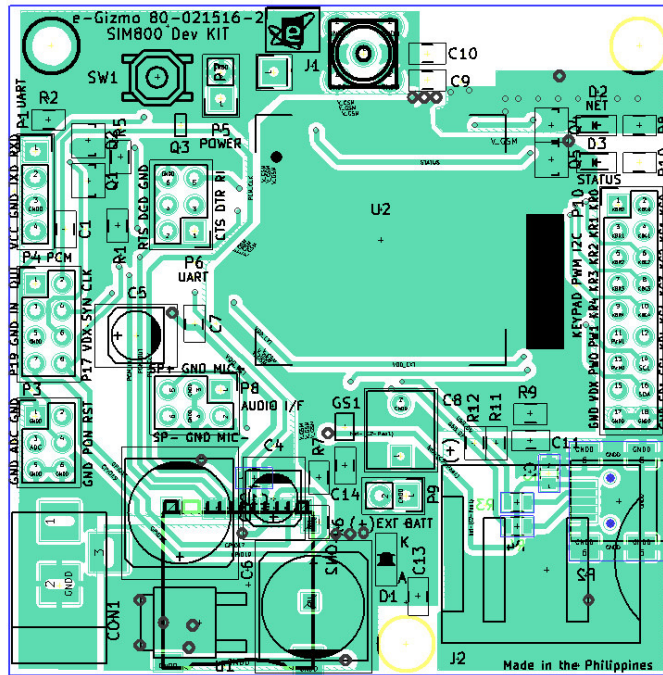

Figure 7. Bottom Guide PCB Layer

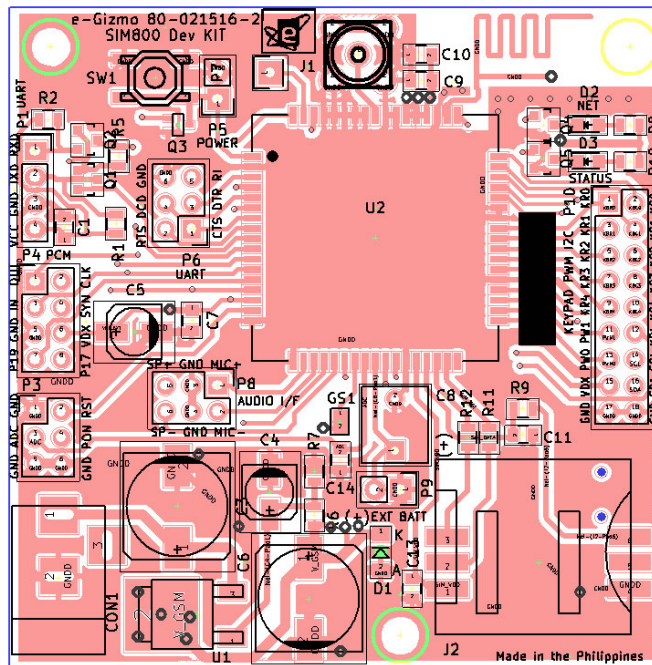

Figure 8. Top Guide PCB Layer