

Contactless Liquid Level Detector XKC-Y26-PNP



Technical Manual Rev 1r0

Intelligent contactless level sensor/detector adopts advanced signal processing technology and high speed signal processing chip, the container thickness will be less relevant to the level measuring, and to the level height of the sealed container, the real non-contact measurement is realized. The level sensor will be mounted in the high/low of the outer container



General Specifications:

This sensor is the most ideal level measuring sensor for various toxic material, strong acid, strong alkali and various liquid in the high pressure sealed container. There will be no special requirements for the liquid medium and vessel material, it's widely used.

Power Input: 5V ~ 24VDC
Current Consumption: 200uA
Output Voltage (HIGH): 5~24VDC
Output Current: 1~100mA
Response Time: 500ms
Working Temperature: 0-100 degrees Celcius
Induction Thickness Range: 0-22mm
Humidity: 5%-100%
Protection Grade: IP67
Dimensions: 25.4mm x 28.2mm x 16.8mm

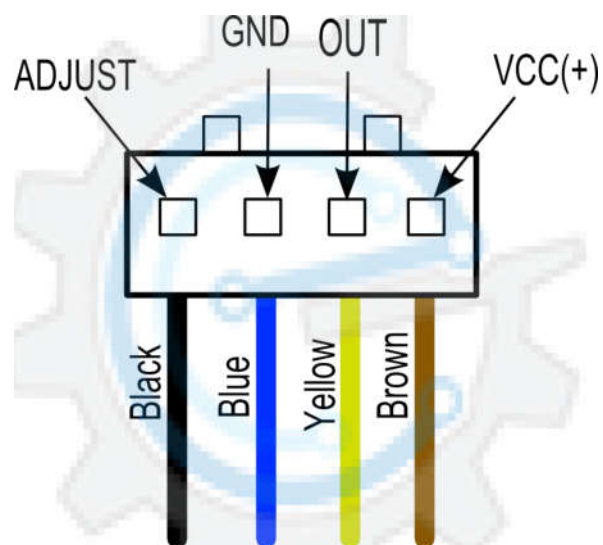
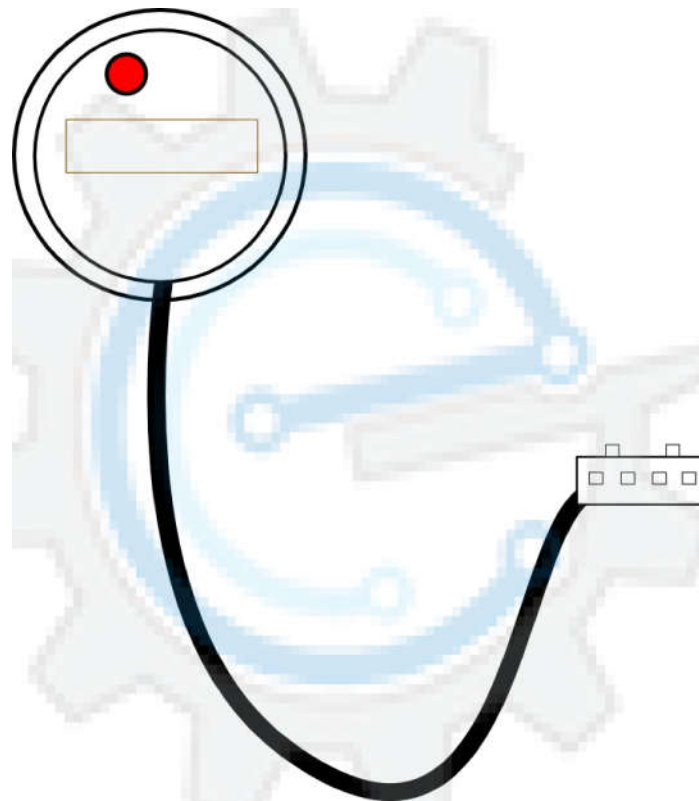

Figure 1. Liquid level detector pinouts

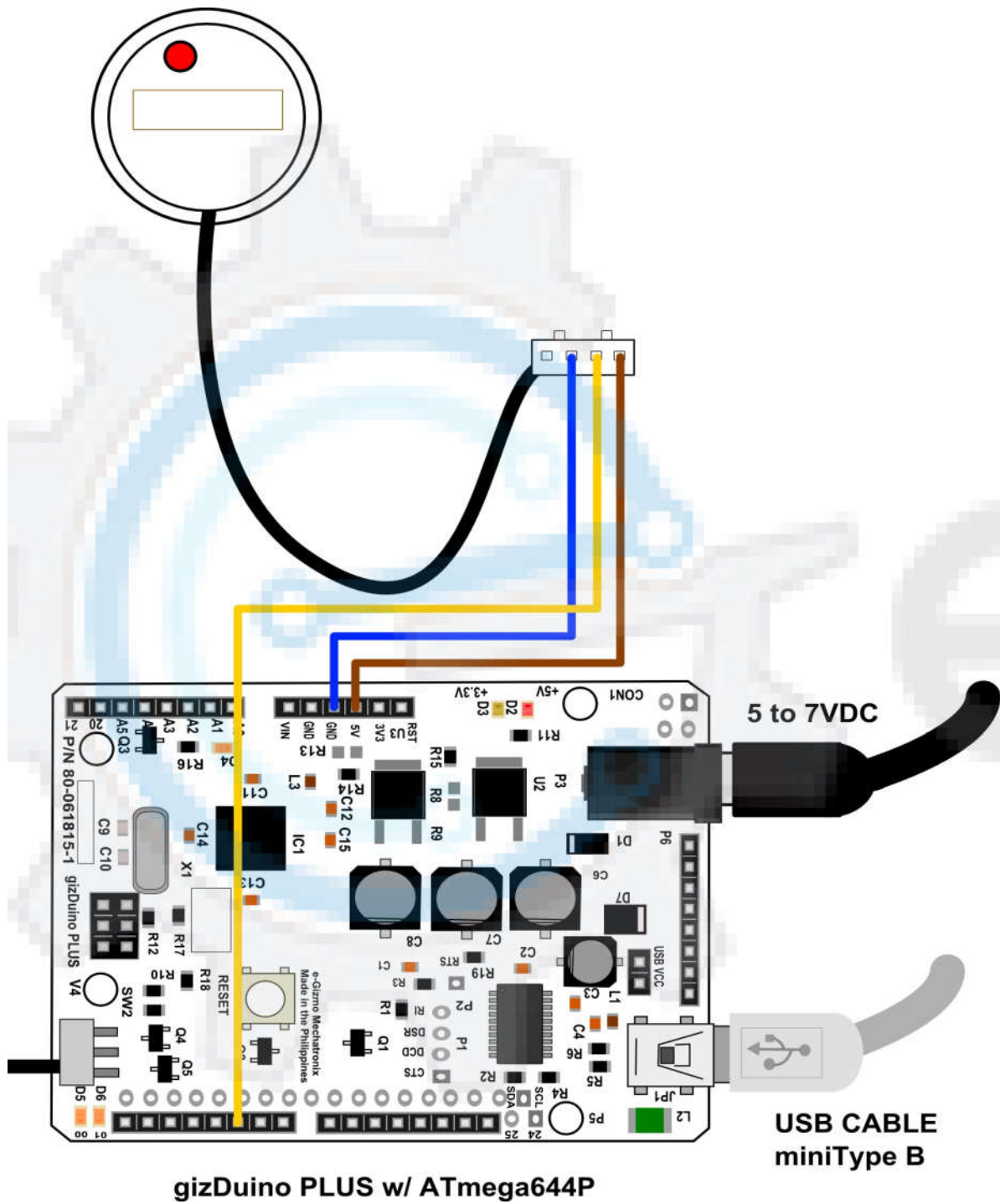

Figure 2. Sample connections

- 1: Non-contact liquid level sensors for non-metallic wall of the container without direct contact with the liquid, are not subject to corrosion acid and alkali and other corrosive liquids, or other debris from the scale effect.
- 2: Intelligent level adjustment and level memory function, level status display, multi-point serial connection; supports NPN Output, high-low level output, PNP output,RS485 signal output
- 3: Detection is accurate and stable, can detect boiling water level
- 4: Pure electronic circuit structure, non-mechanical work, life durability and stable performance
- 5: High stability, high sensitivity, strong interference ability, free from external electromagnetic interference, there are special treatment for frequency interference and common mode interference, compatible with all 5 ~ 24V Power Adapter in the market
- 6: Strong compatibility, penetrate various non-metallic containers, such as plastic, glass, ceramics and other containers, sensing distance up to over 10mm; liquid, powder, particulate matter can be detected
- 7: Open collector output, wide voltage range (5V ~ 12V Or 12V ~ 24V), Suitable for connecting various circuits and product applications

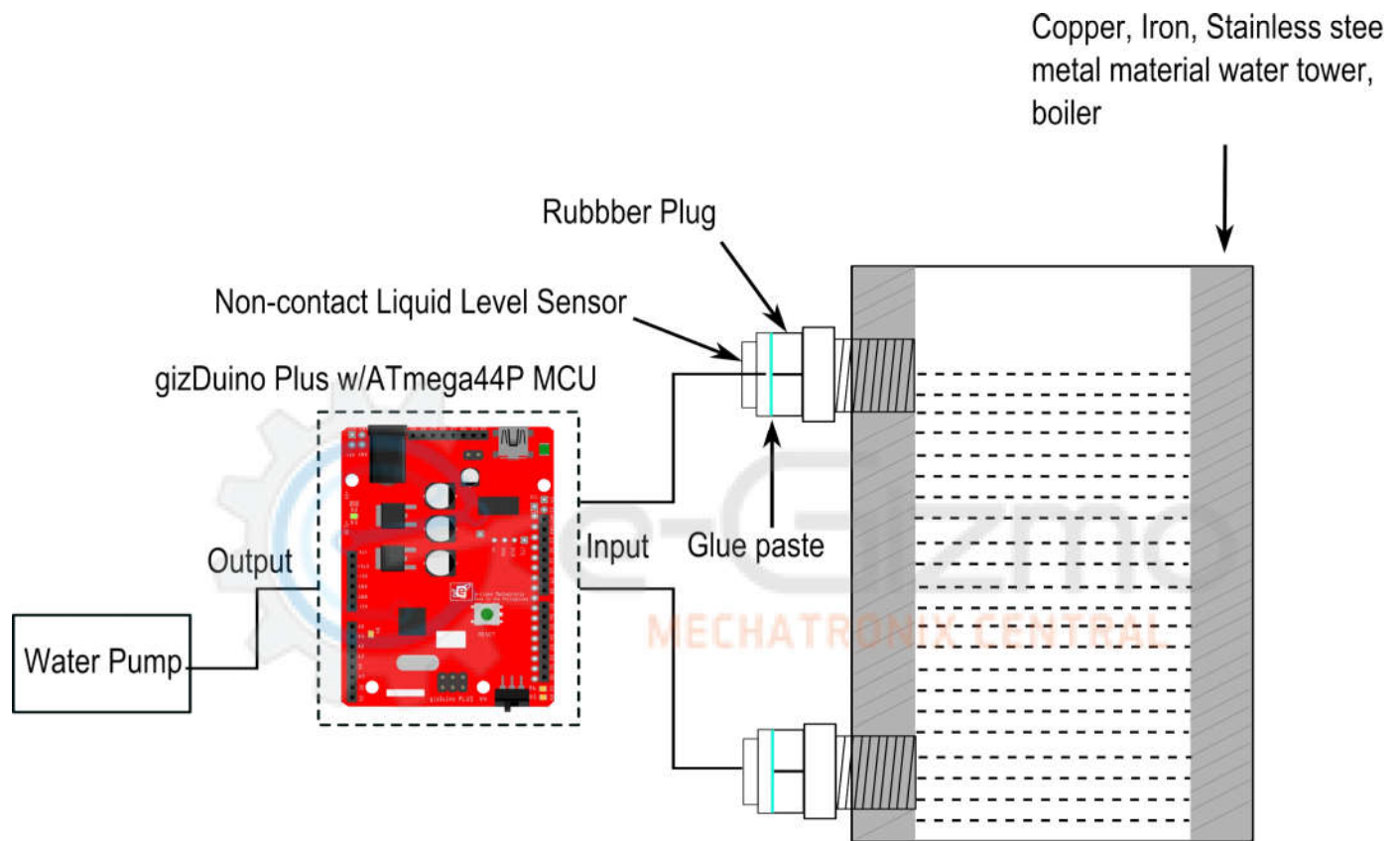

Figure 3. Sample installation with tank

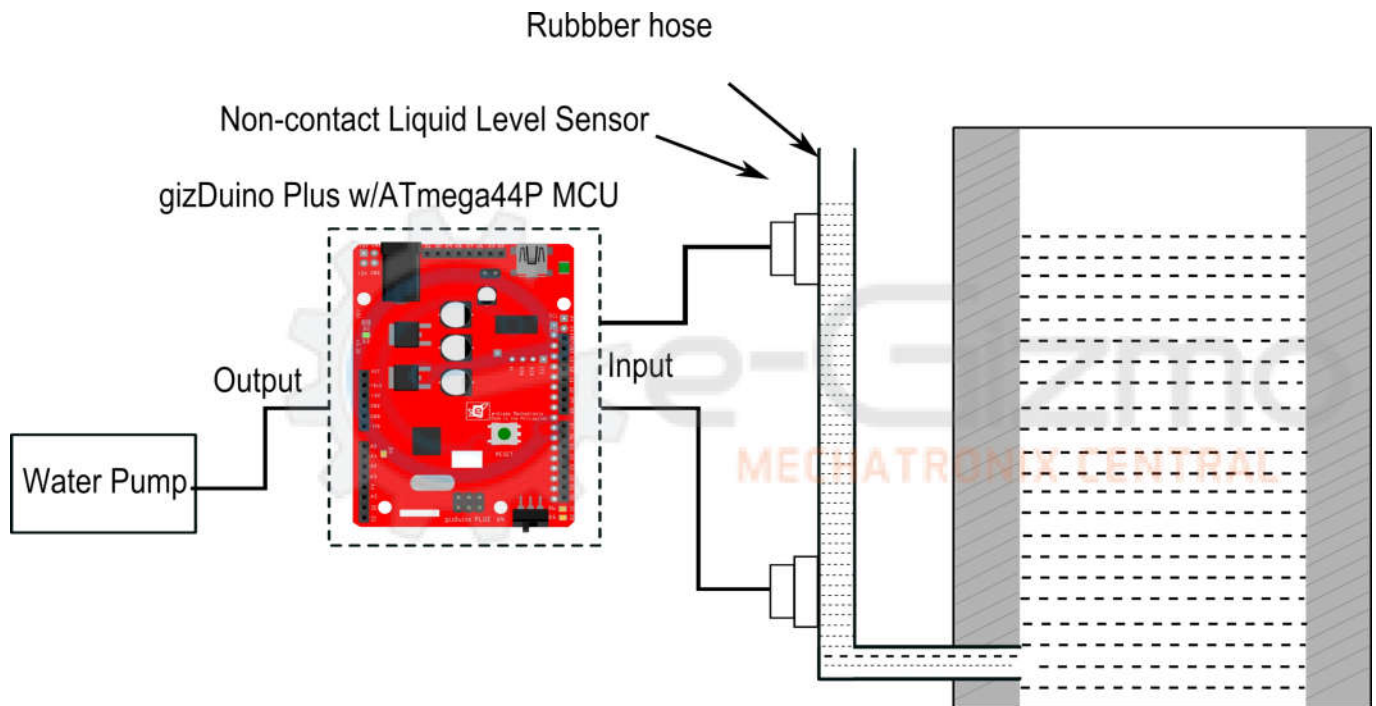

Figure 4. Sample installation with hose

Upload this code to the gizDuino PLUS Microcontroller.
then Open the Serial Monitor to see the output value.

```

//*****//
//      Contactless Liquid Level Detector      //
//      XKC-Y26-PNP                            //
//                                              //
//  A simple sketch to get the signal output data of the liquid //
//  level detector module. A non-contact liquid level sensors //
//  for non-metallic wall of the container without direct //
//  contact with the liquid. Supports PNP Ouput, high-low level //
//  output. Compatible in all gizDuino boards. //
//  Output: 1 = liquid detected, 0 = no liquid detected //
//                                              //
//      by e-Gizmo Mechatronix Central //
//      http://www.e-gizmo.com //
//                                              //
//*****//

//READ STATE
int LIQUID_LEVEL=0;
//PIN ASSIGNMENT
int INPUT_PIN = 5;

void setup(){
  //INITIALIZE
  Serial.begin(9600);
  pinMode(INPUT_PIN,INPUT); //PIN IS SET AS INPUT
}

void loop() {
  //READING THE OUTPUT
  LIQUID_LEVEL=digitalRead(INPUT_PIN);

  //PRINTING THE DATA
  Serial.print("LIQUID LEVEL = ");

  //CONVERT IT TO DECIMAL
  Serial.println(LIQUID_LEVEL,DEC);

  //DELAY
  delay(500);
}

```

Figure 5. Serial Monitor

Output: 1 = liquid detected,
0 = no liquid detected.

