

Gizduino+ Mini 164P/324P/644P

Technical Manual Rev 1r0

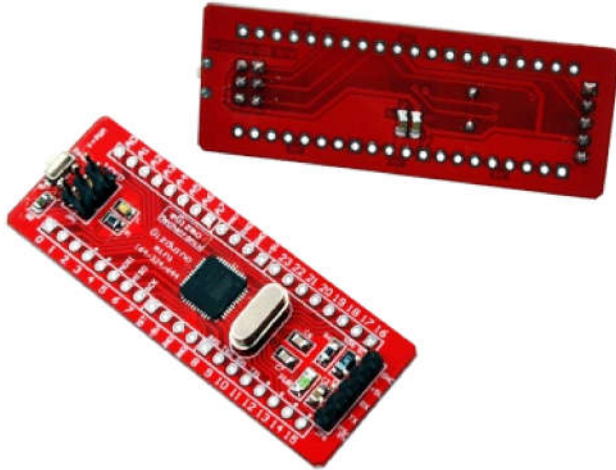

Three variants to choose from:

- **ATMEGA644P** 64K Program Memory
- **ATMEGA324P** 32K Program Memory
- **ATMEGA164P** 16K Program Memory

gizduino+ series are Arduino™ IDE compatible and Sanguino inspired boards that features more I/O - 12 additional I/Os, over the standard gizduino* we are already accustomed with. Using a more feature rich picoPowerAVR chip ATMEGA644P/324P/164P, you are now afforded with an additional hardware UART port (Serial1), and one more SPI channel, all of which are configurable as general purpose digital I/O.

*gizduino is a hardware platform compatible with Arduino™.

FEATURES:

- Arduino software compatible board
- 40- PIN 600 mil DIP size pin layout
- Compatible with breadboard, protoboards and IC sockets
- 32 I/Os (12 more I/Os compared to gizduino)

GENERAL SPECIFICATION:

Power Input :

4.5V-5.5V,
5.0V Nominal

Clock Frequency :

16MHz (ATMEGA 164,324,644)

Programming Ports:

Arduino & ICSP

PCB Dimension:

61L mm x 23W mm

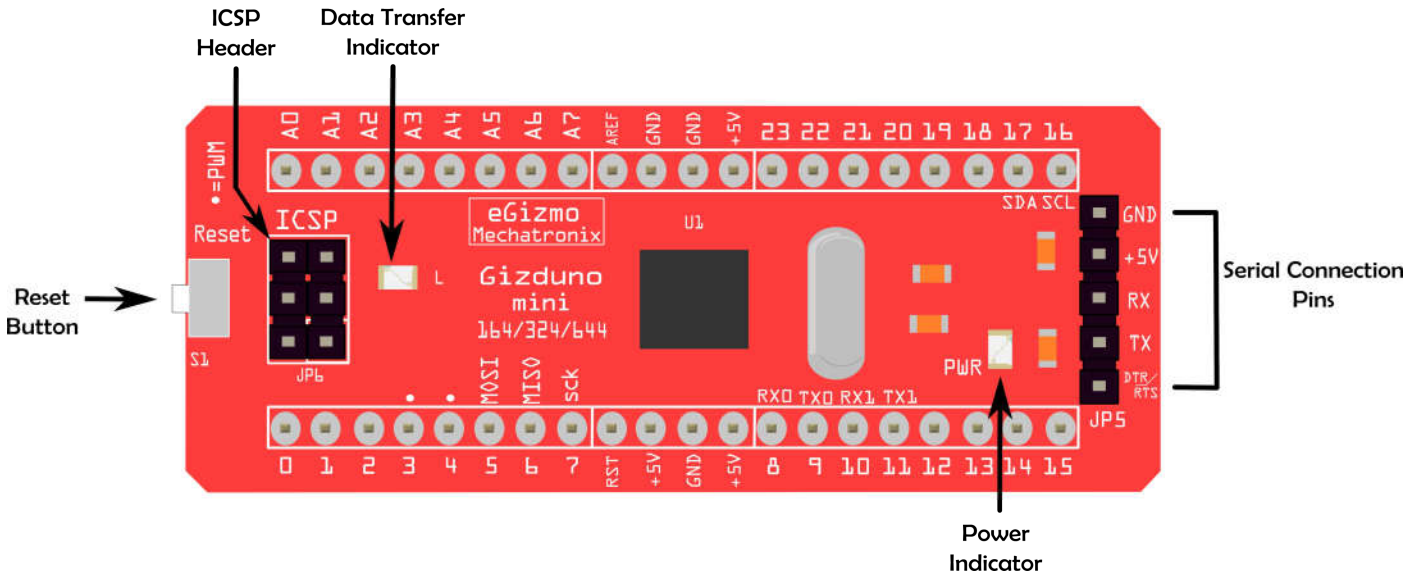

Figure 1. Major parts of Gizduino + MINI Atmega 164/324/644

Table 1. CON1 SPI Connection

Device	Flash Memory	EEPROM	RAM	Speed	Boothloader
ATMEGA 164P	16K bytes	512 bytes	1K bytes	16MHz	Optiboot
ATMEGA 324P	32K bytes	1K bytes	2K bytes	16MHz	Optiboot
ATMEGA 644P	64K bytes	2K bytes	4K bytes	16MHz	Optiboot

Table 2. JP2

Pin ID	IC Pin Function	IC Pin Number	Arduino Designation
RST	Reset	4	Reset
+5V	Vcc	5	5V Power Supply IN
GND	Gnd	6	Ground
GND	Gnd	6	Ground

Table 3. JP3

Pin ID	IC Pin Function	IC Pin Number	Arduino Designation
AREF	AREF	29	Analog Reference pin for A/D Converter
GND	Gnd	28	Ground
GND	Gnd	28	Ground
+5V	AVcc	27	5V Power Supply IN

Table 4. JP4

Pin ID	IC Pin Function	IC Pin Number	Arduino Designation
7	(SCK)PB7	3	Digital I/O, SCK
6	(MISO)PB6	2	Digital I/O, MISO
5	(MOSI)PB5	1	Digital I/O, MOSI
4	(SS/OC0B)PB4	44	Digital I/O, PWM
3	(AN1/OC0A)PB3	43	Digital I/O, PWM
2	(AN10/INT2)PB2	42	Digital I/O
1	(T1/CLKO)PB1	41	Digital I/O
0	(XCK0/T0)PB0	40	Digital I/O, L

Table 5. JP5

Pin ID	IC Pin Function	IC Pin	Arduino Designation
DTR/RTS	-	-	Data Terminal Ready
TX	(TXD0)PD1	10	TX / Digital I/O
RX	(RXD0)PD0	9	RX / Digital I/O
+5V	AVCC	27	+5V device power supply
GND	GND	28	Ground

Table 6. JP6

Pin ID	IC Pin Function	IC Pin	Arduino Designation
MISO	SPI Bus Master Input/ Slave Output	(MISO)PB4	MISO
SCK	SPI Bus Master clock Input	(SCK)PB5	SCK
RESET	RESET	RESET	RESET
+5V	Digital supply voltage	VCC	+5V
MOSI	SPI Bus Master Output/Slave Input	(MOSI)PB3	MOSI
GND	Ground	GND	GND

Table 7. JP7

Pin I.D	IC Pin Function	IC Pin Number	Arduino Designation
A0	PA0(ADC0)	37	Analog/Digital I/O 0
A1	PA1(ADC1)	36	Analog/Digital I/O 1
A2	PA2(ADC2)	35	Analog/Digital I/O 2
A3	PA3(ADC3)	34	Analog/Digital I/O 3
A4	PA4(ADC4)	33	Analog/Digital I/O 4
A5	PA5(ADC5)	32	Analog/Digital I/O 5
A6	PA6(ADC6)	31	Analog/Digital I/O 6
A7	PA7(ADC7)	30	Analog/Digital I/O 7

Table 8. JP8

Pin ID	IC Pin Function	IC Pin Number	Arduino Designation
8	(RXD0)PD0	9	Digital I/O, RX0
9	(TXD0)PD1	10	Digital I/O, TX0
10	(RXD1/INT0)PD2	11	Digital I/O, RX1
11	(TXD1/INT1)PD3	12	Digital I/O, TX1
12	(XCK1/OC1B)PD4	13	Digital I/O, PWM
13	(OC1A)PD5	14	Digital I/O, PWM
14	(OC2B/ICP)PD6	15	Digital I/O, PWM
15	(OC2A)PD7	16	Digital I/O, PWM

Table 9. JP9

Pin ID	IC Pin Function	IC Pin Number	Arduino Designation
23	(TOSC2)PC7	26	Digital I/O
22	(TOSC1)PC6	25	Digital I/O
21	(TDI)PC5	24	Digital I/O
20	(TDO)PC4	23	Digital I/O
19	(TMS)PC3	22	Digital I/O
18	(TCK)PC2	21	Digital I/O
17	(SDA)PC1	20	Digital I/O, SDA
16	(SCL)PC0	19	Digital I/, SCL

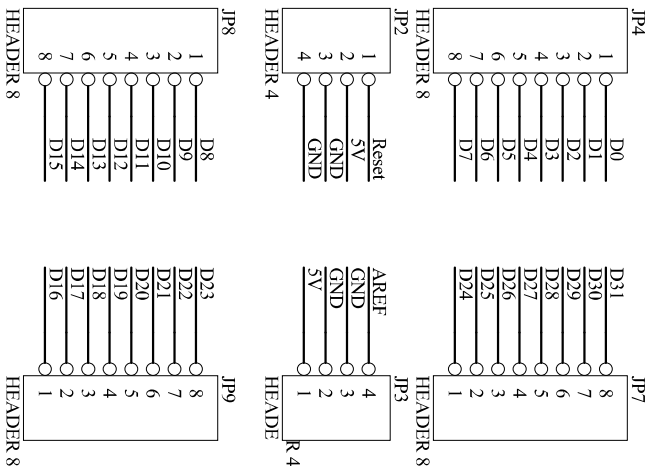
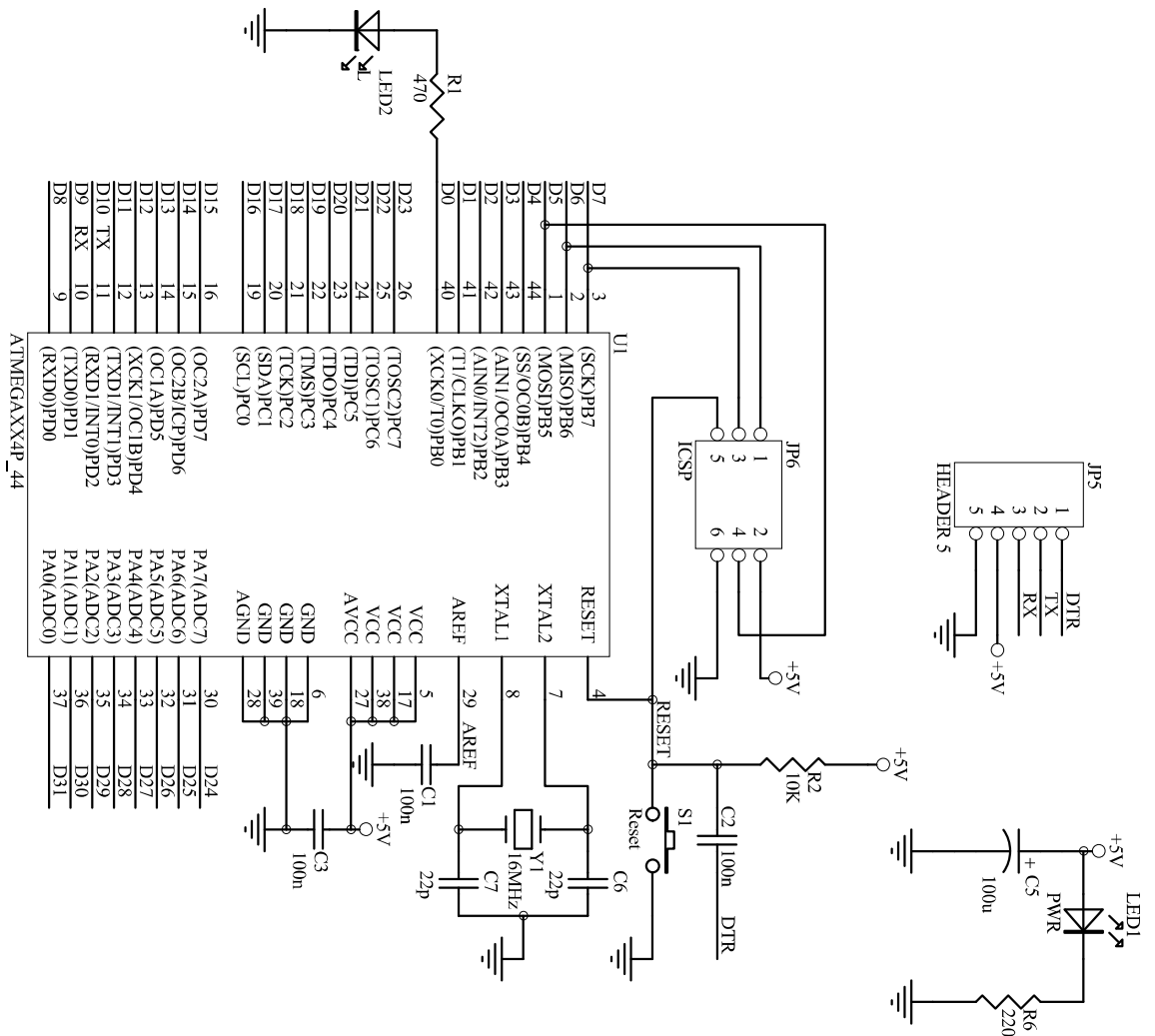

Figure 2. Schematic diagram of Gizduino + MINI ATmega164/324/644



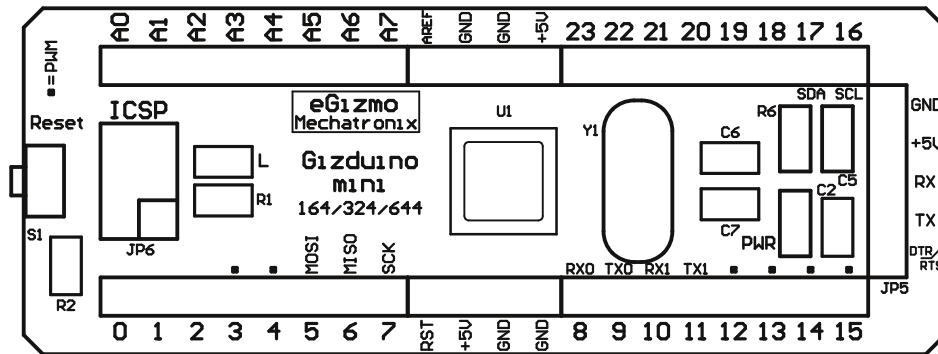

Figure 3. Parts Placement

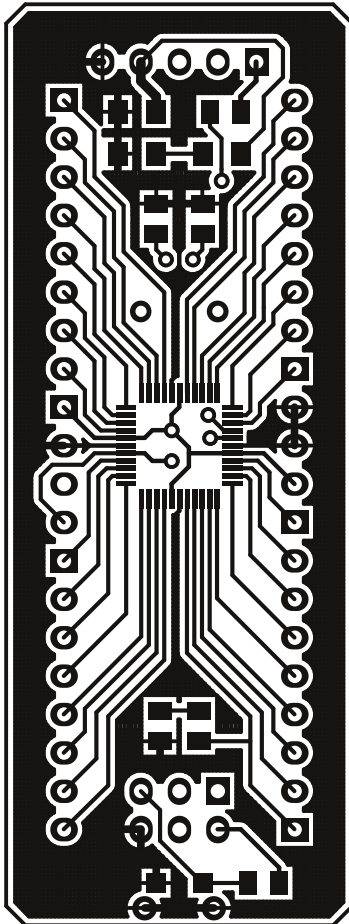

Figure 4. PCB Top Layer(F.Cu)

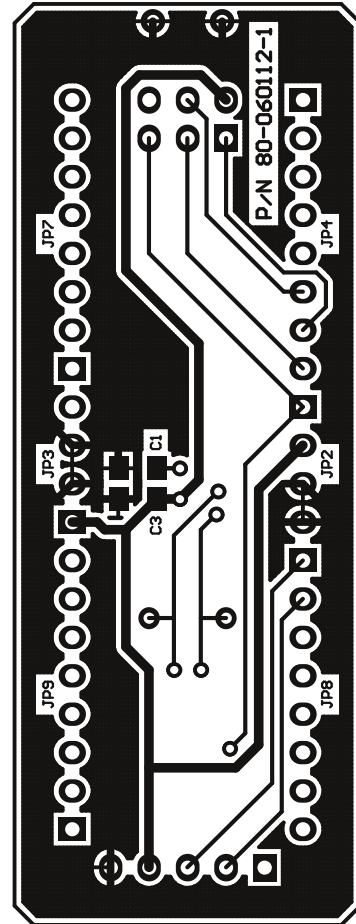

Figure 5. PCB Bottom Layer(B.Cu)

Gizduino +MINI		USB to UART
GND		GND
+5V		+5V
RX		TX
TX		RX
DTR/RTS		DTR

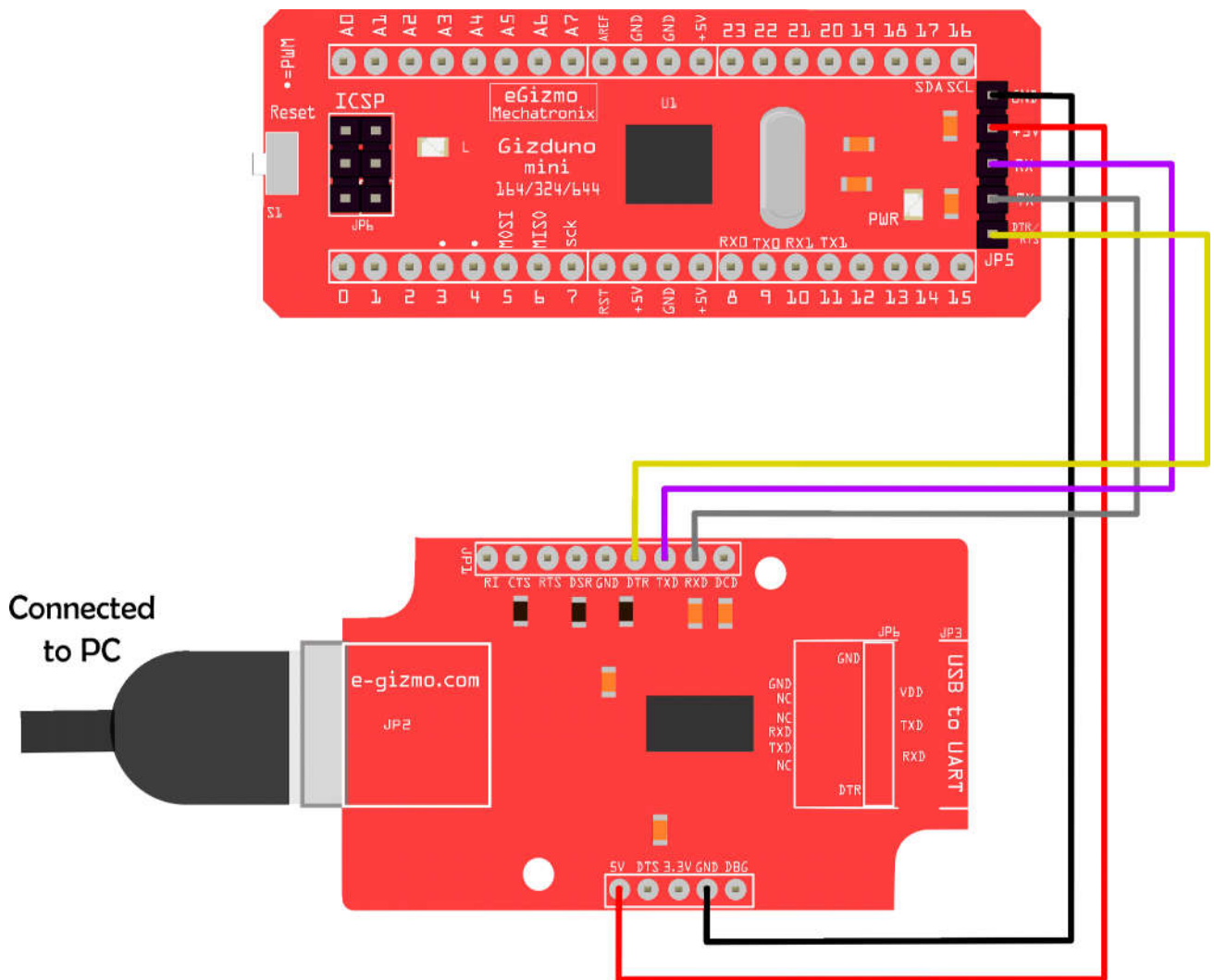

Figure 6. Sample Application for Gizduino + MINI 164P/324P/644P with USB to UART (Serial-TTL).

Open Arduino IDE.
 File>Examples>Basics>Blink.
 Change the led = 13 to led = 0;
 Tools>Board>Gizduino+(mini)ATmega644(Sanguino Mode).
 Select the COM PORT. Tools>Serial Port>COM #.
 Then Click UPLOAD.

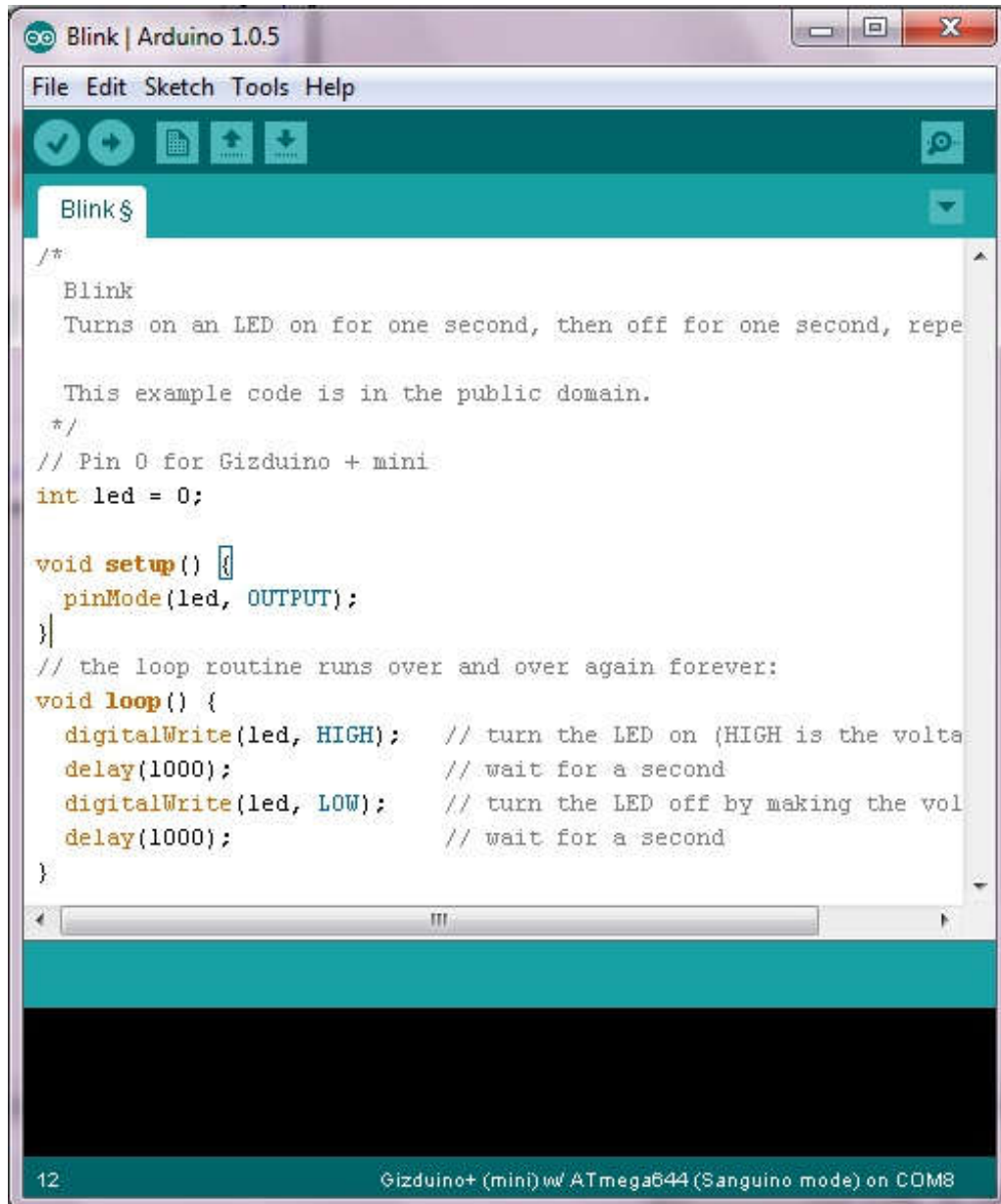

Figure 7. Blink Test for Gizduino + mini (Sanguino Mode)